

Motor drive 3133.00



Description

Compact 24 V DC motor with worm gear and continuous hexagon socket. Although the drive was developed for ergonomic table applications, it can be used in many other fields. A cable with AMP plug and an integrated Hall sensor allows easy and secure control of the entire system.

Special features

- Two integrated Hall sensors for measurement of the revolutions and direction of rotation
- Through going hexagon socket in wrench widths 6 mm, 7 mm, 9 mm
- Good self-locking properties
- Low noise
- 1000 mm motor cable with connector included
- Can be combined with all Ketterer spindle systems

Variant key

The variants are formed by the different wrench widths.

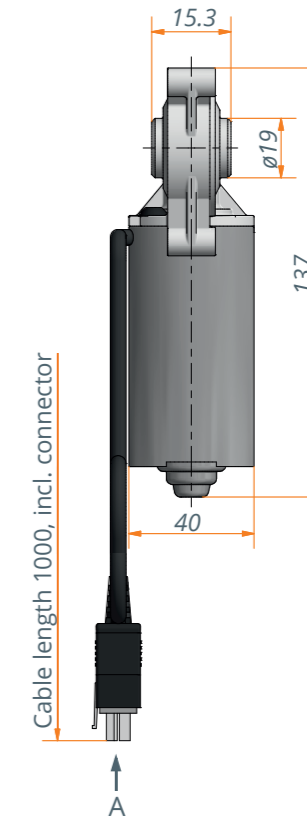
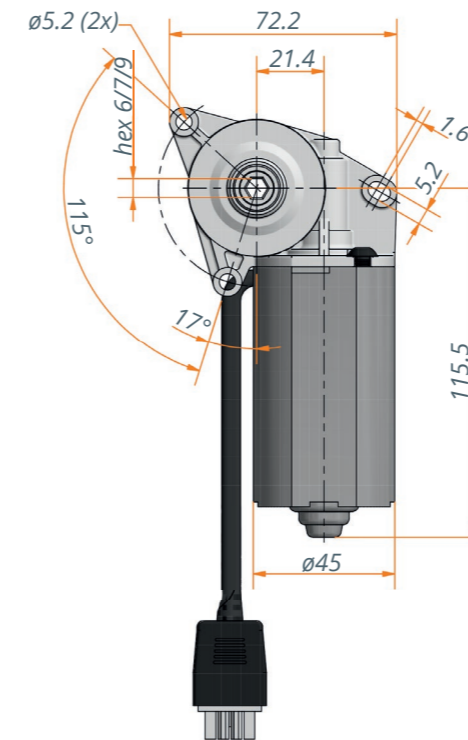

Technical data

Model	3133.00-0016	3133.00-0017	3133.00-0011
Motor	DC motor 24 V	DC motor 24 V	DC Motor 24 V
Sensor/Power supply	Hall/5 V DC/0.3 A	Hall/5 V DC/0.3 A	Hall/5 V DC/0.3 A
Protection class	IP30	IP30	IP30
Idle running speed	120 rpm (24 V)	120 rpm (24 V)	120 rpm (24 V)
Duty cycle idle speed	20% (at 5 min.)	20% (at 5 min.)	20% (at 5 min.)
Rated torque*	3.5 Nm	3.5 Nm	3.5 Nm
Duty cycle nominal load	20 s ON 4 min OFF	20 s ON 4 min OFF	20 s ON 4 min OFF
Short term peak torque (<1sec)	5 Nm	5 Nm	5 Nm
Input	hex 6 mm	hex 7 mm	hex 9 mm

* Determined at full load for service life of 10,000 double strokes

Pin assignment

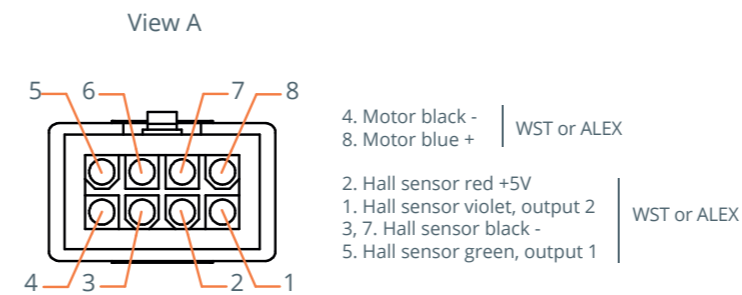

Installation position/Mounting

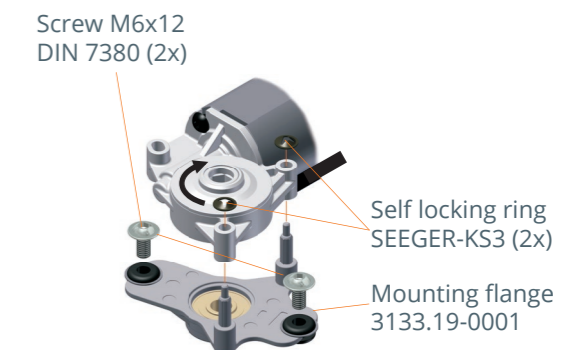

Technical notes

- To ensure secure operation the motor must be operated in the predefined installation position (see installation position/mounting).
- The drive working range (nominal torque) is determined for a service life of 10,000 double strokes.
- The connection position of the drive in the entire system with vibration damping elements can be beneficial. However, the functional reliability position of the drive in the application should be tested.
- Through the controller* the system is regulated such that the speed in the entire drive working range is kept as constant as possible.
- By using a controller with a short-circuit brake the holding torque position of the drive can be increased.

* In combination with LogicData control box Compact-3