

Pin 1: Motor black -  
Pin 2: Motor blue +

Pin 3: Hall sensor, red, +5V  
Pin 4: Hall sensor, violet, output 2  
Pin 5: Hall sensor, black -  
Pin 6: Hall sensor, green, output 1

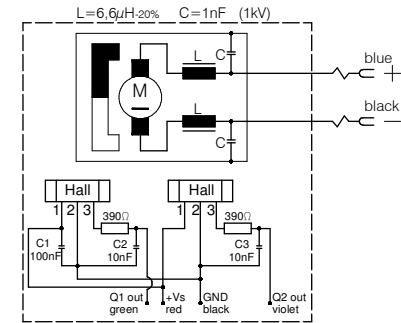

HALL SENSOR:  
Diodes AH3761 SC54  
Infineon TLE 4961-1K  
Infineon TLE 4946-2K  
or UL EQUAL

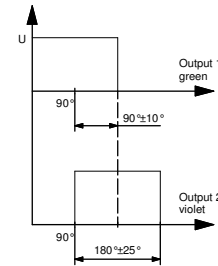

PIN assignment

wire 0,75mm<sup>2</sup> (2x)  
colour: black, blue  
pin type AMP 170364

wire 0,25mm<sup>2</sup> (4x)  
colour: red, violet, black, green  
pin type AMP 170363